



THG2000 Bread Bagger

2000/2100 Bread Bagger



- Features:
- 40-75 Bags Per Minute
 - Low Maintenance Timing Belt Drive
 - Easy Release High Speed Cam
 - Cripple Reduction Features
 - Remote Scoop Adjuster
 - Bag Tension Adjustments
 - Lexan Hoods with Gas Springs
 - Minimum Downtime
 - Ease of Maintenance
 - Adjustable Length Wicket Tables
 - Flusher Bar Adjustments
 - Quick Change Scoops
 - 6' Stainless Infeed Conveyor
 - Nylatron Roller Assembly
 - Stainless Vacuum Nozzles
 - Quick Adjustable Guides
 - Dual Air/Vacuum System
 - Stainless Steel Construction
 - Adjustable Feet with Swivel Base
 - Product Preset Counter
 - Scheduled Maintenance Indicator
 - Infeed Flight Phase Changer
 - Product Totalizer Counter
 - Double Loaf Eliminator

800.356.7591



2000/2100 Bread Bagger

Typical Bagger Layout - Left Hand Shown

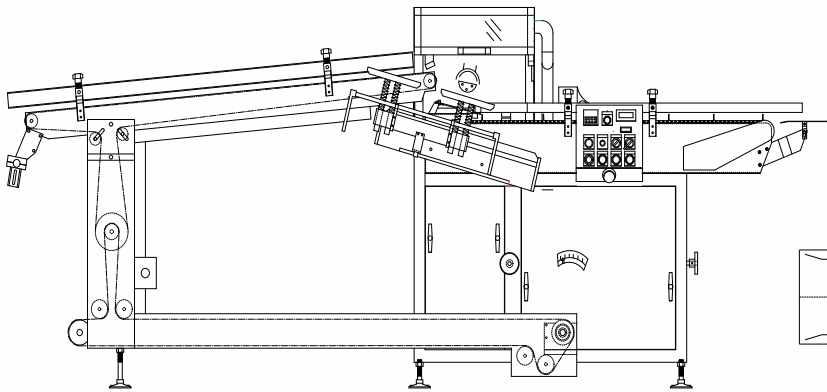

Side View

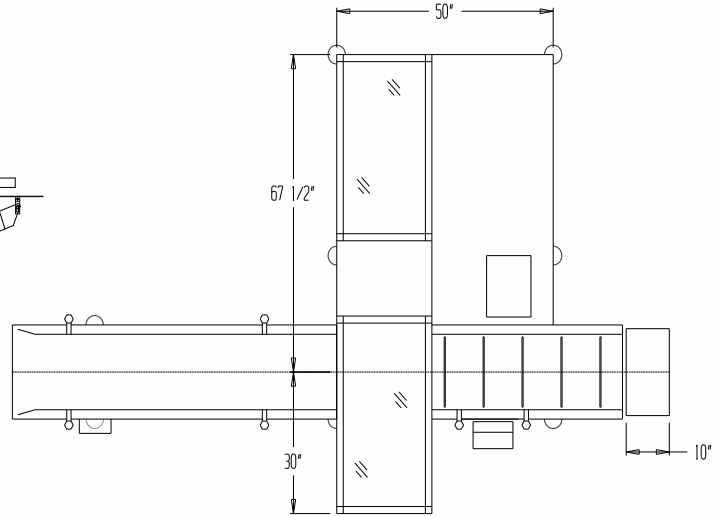

Top View

Standard Features:

- Stainless Steel Frame, Body, and Lower Door Panels
- 64" Stainless Steel Flighted Discharge Conveyor
- Removable Lower Access Door Panels for easy Maintenance
- Lexan Hoods with Gas Springs
- Safety Switches on Lexan Hoods
- Flusher Bar Adjustments
- One set of quick change bag scoops (customer specifies sizes)
- Low Maintenance Timing Belt Drive with Variable Speed Motor
- Horton Air Clutch
- Easy Release High Speed Cam and Blockade Assembly
- Manual Wicket Changer with Top Air Bag Inflator
- Adjustable Length Wicket Tables
- Wired for buyer's three phase voltage: 230/460vac.
- Adjustable Feet with Swivel Base
- Slicer Conveyor Overload Clutch with Momentary Dropout Switch
- Bag Tension/Remote Scoop Adjuster "on the fly adjustments"
- Power Panel Door Disconnect
- Bag Transvector and Bag Skirt for stabilizing bag flutter
- AC Inverter with Speed Dial Control
- 6' Stainless Infeed Conveyor with 7 Flights
- Double Loaf Eliminator
- Dual Air/Vacuum System with Stainless Steel Manifolds
- Product Preset Counter with Alarm
- Product Totalizer Counter
- Digital Speed/Bags Per Minute Indicator
- Regular Scheduled Maintenance Indicator
- Infeed Flight Phase Changer

Model THG2000/2100

Specifications:

- Maximum Loaf Size
Length 16"(406mm). Width 5 1/2" (140mm). Height 6" (152mm).
- Rated Speed
Variable Speed up to 75 loaves per minute
- Electrical Requirements
230/460 Volt, 60Hz, 3-Phase AC 20 amp. service for 2 HP Drive Motor. Power for Auxiliary Equipment are provided with a 10 amp breaker for additional service.
- Air Requirements
12 CFM @ 90-100 psi.
- Weight (Approximate)
1650 lbs. Net (750 kg), 1850 lbs. Shipping weight (840kg), 2650 lbs. Export (1250kg).
- Construction
Stainless Steel Body, Frame, Guards. Lexan Hoods. Stainless Steel Scoops.

Optional Equipment:

- 110 volt Outlet with 2KVA Transformer for Auxiliary Equipment
- Additional Sets of Quick Change Scoops
- Discharge Conveyor Extensions or Modifications (73", 82", 91")
- Burford Model 2000/2100 Bag Tyer w/ optional upgrades
- Kwick Lock Model 872B, 1082, & 1011 Closing System
- Spare Parts Package



The
Henry
Group,
Inc.

P.O. Box 8246 Greenville, TX 75404

800.356.7591 903.883.2002 Fax: 903.883.3210

www.thehenrygroup.com email: sales@thehenrygroup.com